

USER MANUAL

WIDE DYNAMIC RANGE OSD ICR DAY/NIGHT DIGITAL COLOR CAMERA

1/3" HIGH RESOLUTION

12VDC + 24VAC / 100V~240VAC

1. General description

This 1/3" RGB DSP *Wide Dynamic Range Day/Night Camera*, with high resolution picture elements, and advanced Digital Signal processor to provide an unprecedented optimal image with vivid and stable true color picture up to 540TVL.

2. Features

- a. *Wide Dynamic Range*: filtering intense back light surrounding a subject and thus produce viewable background with clear subject up to max 120dB contrast level.
- b. *Resolution*: performing of 540TV line.
- c. *Sense Up*: By effectively increase exposure time in a low light condition; therefore increases the sensitivity of the camera to produce a crystal clear image, up to 32X.
- d. *White Balance*: Auto Tracing White balance (ATW) allowing the camera to adjust color tone automatically according to the color temperature of the light source illuminating the subject.
- e. *Back Light Compensation*: Smart digital control Auto BLC, enable the camera to be used against any unusual back light conditions.
- f. *Auto Exposure System*: Advanced Auto Exposure System for auto iris lenses controlling the amount of light to ensure the optimal picture quality.
- g. User selectable sync Internal 1 or Internal 2 or external *Line-lock* mode.
- h. User define OLPF switching from real time (1sec) ~ 255 sec.
- i. *On Screen Display* (OSD) easy control.
- j. Smart mechanical IR cut OLPF Day/Night auto switching.

3. Name of parts and functions

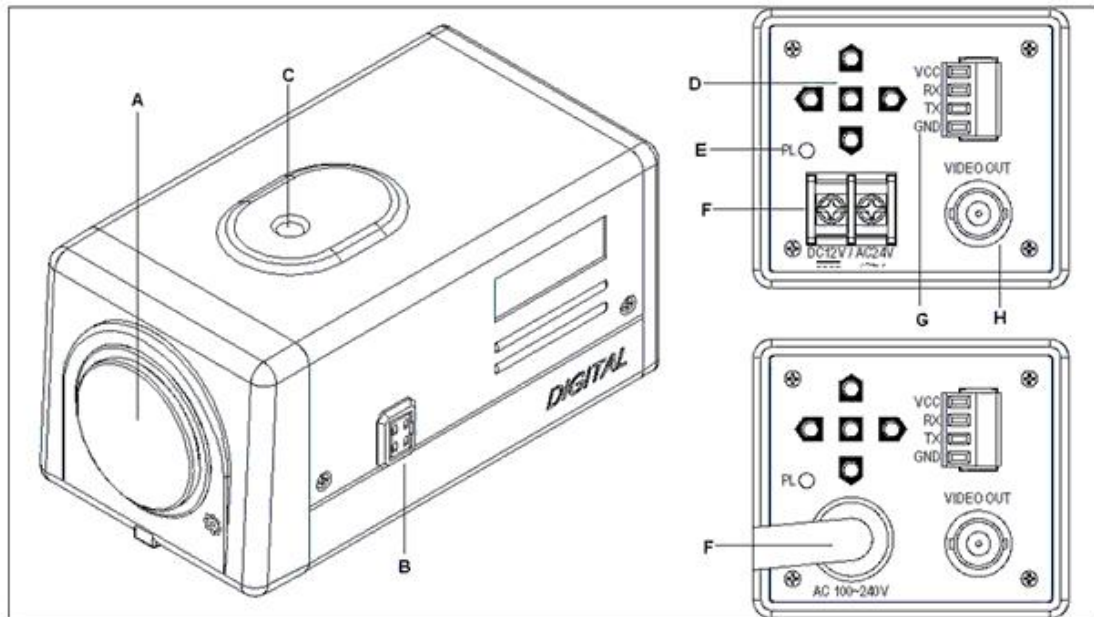

A. C (CS) mount adaptor

If a CS mount is to be used, remove the C mount ring.

B. Auto Iris lens connector (Mini Jack), see 3.1 auto iris lens connector.

C. Camera mounting screw hole

Standard photographic pan-head screw size (1/4"-20)

D. OSD manual push bottoms

a. push on the "Enter" bottom for two seconds to shown the OSD screen on the monitor.

b. Push enter-bottom to enter any sub-manual

c. after select the desire setting, push down-bottom to exit, and goes one step up to the previous manual

d. push down-bottom to Prev. and push enter to go one step up the manual

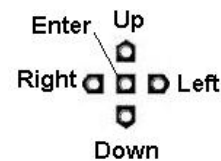

E. Power LED

F. DC12V/AC24V or AC100~240VAC Terminal block, see 3.2 Power Terminal

G. RS232 ports:

VCC: 3.3V power output

RX: transmitter

TX: receiver

GND: power for ground

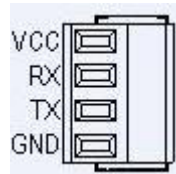

H. Video output terminal (BNC): to provide video signals output.

Warning : To prevent fire or electric shock hazard, do not expose the appliance to rain or moisture.

3.1. Auto Iris Lens Connector

Use the accompanying auto iris lens connector plug.
For auto iris lens with built-in EE amp. (VIDEO Type)

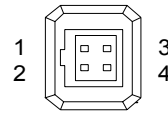

Set the Iris selector switch to “Video” position.

Connector cable leads definition:

- 1.Red----power 2.NC
- 3.White----video 4.Black----shielded

For auto iris lens without EE amp. (DC Type)
The connector drawing shows external view from camera.

Set the lens iris selector switch to “DC” position.

Connector cable lead definition:

- 1.Damping coil (-) 2.Damplng coil (+)
- 3.Driving coil (+) 4.Driving coil (-)

Connect the leads as shown above; please refer to the instructions of the lens for more detail.

3.2. Power Terminal

3.2.1 AC 24V/DC 12V model

This terminal block accepts both polarity protected AC 24V and DC 12V.



3.2.2 AC 100V~240V model

For AC 100V to 240V models, the camera is equipped with a universal switching power supply.
It can accept power source input from 100VAC to 240VAC

4. **OSD** functions: push on the “Enter” bottom for two seconds to shown the OSD screen on the monitor, and the following manual appears:

WDR MODE: filtering intense back light surrounding a subject and thus produce viewable background with clear subject up to max 120dB contrast level.

EXPOSURE: Setting of Auto Gain Control, Slow Shuttle (Sense Up), WD Range and Backlight Zone.

WHITE BALANCE: Auto Tracing White balance (ATW) allowing the camera to adjust color tone automatically according to the color temperature of the light source illuminating the subject.

VIEWING: Settings of mirror effects, sharpness, Gamma and resolution presets

SETUP: IRIS, Video I/O, ID setups, Day/Night setup

SAVE/RESTORE: Restore and set user’s setting or default factory settings

EXIT: Exit of OSD manual

Details break down chart:

4.1. **WDR mode: Normal**

Normal/Indoor/Outdoor/Fluor1/Fluor2/NTSC50Hz

Selections of the above for appropriate camera environments settings

4.2. **Exposure:**

4.2.1 Gain Mode: Slow Shutter

4.2.1.1AGC

4.2.1.1.1. AGC Medium

Low/Medium/High/Custom

Custom

Bias 0, -18~18

Limit 34, 0~60

Prev./Save/Cancel

*When AGC setting less than D/N Gain, must adjust D/N Gain for application.

4.2.1.1.2. Prev./Save/Cancel

4.2.1.2 Manual

Gain 0, -42~60

Prev./Save/Cancel

4.2.1.3 Slow Shutter (Sense Up)

Slow Shutter 2X: 2X/4X/8X/16X/32X/Off

DE-Chroma 2X: 2X/4X/8X/None

DE-Sharp 2X: 2X/4X/8X/None

Prev./Save/Cancel

*DE-Chroma & DE-Sharp are not available when the setting more than Slow Shutter.

4.2.2 WD Range

B.2.1. Auto

4.2.2.1.1. Range Ctrl: Normal

Low/Normal/High/Custom

Custom

Bias 0, -36~36

Limit 34, 0~60

Prev./Save/Cancel

4.2.2.12. Prev./Save/Cancel

4.2.2.2 Manual

Value 5: 0~10

Prev./Save/Cancel

4.2.3 B.L. zone

On or Off: select the block zone for setting back light area. When into the BL Zone, a square appears, push enter-bottom to change its color when:

B.3.1 White: moving square by pushing up down left right.

B.3.2 Green: expanding square by pushing up down left right.

B.3.3 Red: squeezing square by pushing up down left right.

*Push on the "Enter" bottom for two seconds to exit the BL zone.

4.2.4 Transition Normal

Slow/Normal/Fast

4.2.5 Prev./Save/Cancel

Save changes or cancel or go back to previous page

4.3. White Balance

4.3.1 Mode ATW Extend

4.3.1.1 ATW Normal

White Balance Limit

Low limit 2K~2000~5.5K

High limit 5.5K~7500~11K

4.3.1.2 ATW Desat.

White Balance Limit

Low limit 2K~2000~5.5K

High limit 5.5K~7500~11K

4.3.1.3 AWB

Push AWB Confirm

Save AWB & All Changes

Cancel

4.3.1.4 Manual

4.3.1.4.1. ADJ Mode Color Temp.

Color Temp.

Color Temp. 2K~5000~11K

Prev./Save/Cancel

R/B

Red -18, -20~20

Blue 13, -20~20

Prev./Save/Cancel

4.3.1.4.2. Prev./Save/Cancel

4.3.2 MGNTA Ctrl On

Off/On/Custom

Custom

MGNTA Ctrl 0~11~100

Prev./Save/Cancel

4.3.3 WB BIAS: -2K~0~2K

4.3.4 Transitions

ATW SLEW 10, 1~100

HYST 5, 1~100

Prev./Save/Cancel

4.3.5 Prev./Save/Cancel

4.4. Viewing

4.4.1 H-Mirror Off

On/Off

4.4.2 Gamma Mode Auto

Auto/Manual/Off

Manual

Gamma 25~45~100

Prev./Save/Cancel

4.4.3 Sharpness

D.3.1 Detail Boost Auto

Auto/Off

D.3.2. Noise Reduction On

On/Off

On

CW NR 183, 0~255

D.3.3 Sharpness, -8~0~8

D.3.4 Aperture, -8~0~8

D.3.5 Prev./Save/Cancel

4.4.4 Chroma

BIAS 0, -8~8

Prev./Save/Cancel

4.4.5 Resolution Normal1

Normal1 / Advance1 / Normal2 / Advance2

4.4.6 Prev./Save/Cancel

4.5. Setup

4.5.1 Iris

Lens Select DC

DC/Video/Manual

DC Gain, 0~120~255

Video Gain, 0~50~255

AI Thresh, -42~-18~60

Prev./Save/Cancel

4.5.2 Video I/O

4.5.2.1 Video Standard NTSC

4.5.2.1.1 NTSC/PAL

NTSC

a. Setup On

On/Off

b. Video Level, 80~110~150

c. Color Bar Off

Off/On

4.5.2.1.2 PAL

a. Video Level 80~110~150

b. Color Bar Off

Off/On

c. Prev./Save/Cancel

4.5.2.2 SYNC INT

INT/INT2/LL

Line lock

V-Phase, 0~519~624

Prev./Save/Cancel

4.5.2.3 Prev./Save/Cancel

4.5.3 ID Setup

Camera ID Setup

4.5.3.1 ID Display Off

On/Off

4.5.3.2 Camera ID: _ _ _ _ _

4.5.3.3 ID Position Up-Left

Up-left/Up-center/Up-right/Down-left/Down-right

4.5.3.4 Prev./Save/Cancel

4.5.4 Day/Night Setup

Day/Night Setup

4.5.4.1. D/N mode Auto

Auto/Day/Night

Auto

D/N Gain 26, 0~60

D->N Level 24, 0~60

N->D Level 14, 0~60

D/N Delay 10, 0~255

Prev./Save/Cancel

*When D/N Gain more than AGC setting, must adjust D/N Gain for application.

*D->N Level must less than D/N Gain

*Suggest best setting D->N Level more than N->D Level +10

4.5.4.2. Gain Boost Off

Off/On

4.5.4.3. Prev./Save/Cancel

4.5.5 Prev./Save/Cancel

4.6. **Save/Restore**

4.6.1 Restore user settings

4.6.2 Save user settings

4.6.3 Restore factory settings

4.6.4 Reset Camera

4.6.5 Prev.

4.7. **Exit:** exit of OSD manual

5. **Infra-Red Illuminator**

Under low light condition, ordinary color camera cannot achieve a clear picture when working with IR projector. This camera is specially designed with the capability to accept most IR projector to create a crystal clear mono picture when in a completely dark area.

The range of Infrared wavelength is from 700nm to 1100nm.

The focus may slightly vary with IR wavelength due to the lens diffraction to long-wave, while installing the camera with IR projector, please check the focus under IR projector and normal light condition, and regulate to its best focusing position.

It is recommended to adjust lens aperture accordingly to increase the depth of field in order to compensate the lens diffraction.

*For best operation please utilize an IR illuminator for night vision to avoid the focus shift.

6. Specifications

Power requirements	12V DC + 24V AC	100~240V AC
Synchronization	INT / Line-Lock (for AC POWER)	
Image device	1/3" RGB DSP	
Picture elements	720(H) x 540(V)	
Dynamic Range	102 dB typical, 120 dB max	
Signal System	NTSC/PAL Selectable	
Scanning system	525/60 (NTSC), 625/50 (PAL)	
Horizontal Resolution	540 TVL	
Sensitivity	0.05 lux @ F1.2, 30IRE	
IR wavelength	700~1100nm	
ICR OLPF switching	Auto switching	
OLPF change delay time	User define OLPF switching from real time (1sec.) ~ 255sec.	
Signal-to-noise ratio	Better than 50dB	
Gain	AGC ON/OFF, fully programmable	
Gamma Compensation	Auto / Manual / OFF	
Resolution	4 modes (Normal1 / Advance1 / Normal2 / Advance2)	
White balance	5 modes	
Slow Shutter	Max: 32X	
Mirror	Horizontal ON/OFF	
White balance Range	2000°k~11000°k	
DNR	ON/OFF, fully programmable	
RS-232	YES	
Video output	Composite 1.0 V p-p at 75Ω	
Lens mount	Accept C/CS mount	
Power Consumption	4 W	
Operating temperature	-10°C ~50°C (14 ~ 122)	
Dimensions	60 x 53 x 110mm (W x H x D)	

*Specifications are subject to change without notice.